

Uninterrupted Power Supply

1. Introduction

Uninterrupted power supplies (UPS) are useful for applications when power is required 24 hour per day and 7 days per week (24/7).

Usually, rechargeable power sources (high power batteries) are used as a temporary power source until the main power fault is fixed.

Certain low cost UPS systems use a low voltage and high current battery connected to an inverter. There are also UPS systems with 400 V batteries that need expensive maintenance costs.

This article does not include backup power source monitoring and activation circuits.

2. Applications

Applications include:

- Medical (eg. life support systems, telemedicine, ECG, EEG),
- Transport networks (radars, 24/7 public transport),
- Emergency call centres (Ambulance, Police, Fire Brigade),
- Financial and banking (eg. high value transactions),
- Telecommunications (including telemedicine, mobile phone base stations),
- Supermarkets and shopping centres (eg. fridges) - Many small businesses do not have such power supplies,
- Military and security systems,
- Media (TV and radio),
- Renewable Energy - This includes homes and business that rely mostly on renewable energy (highly influenced on weather) for power,
- Space communications (satellites, remote space probes Moon/Mars/Voyager, Hubble telescope),
- Research (radio telescopes or synchrotrons) - Someone might books a time slot,
- Smart homes - Power control systems,
- Website servers (websites) - Many low cost websites/domains do not have this.

3. Step 1: Design the Circuit

I designed the circuit with Pspice software:

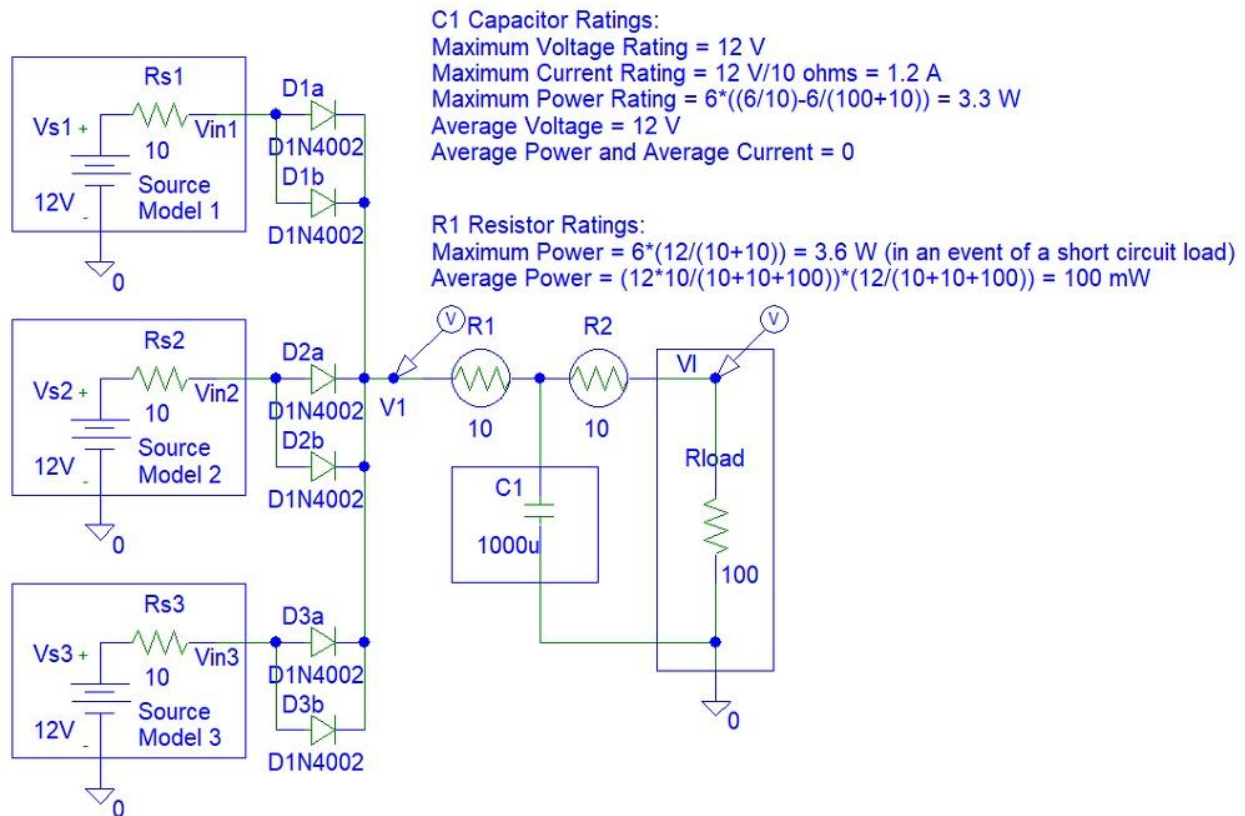

Figure 1: Circuit design

Equivalent resistors seen by the capacitor:

$$R_{th} = (100 + 10) \times 10 / ((100 + 10) + 10)$$

Voltage Across the Capacitor C1: $V_{c1} = V_{th} * (1 - \exp(-t / (R_{th} * C1)))$

Current Across the Capacitor C1: $I_{c1} = V_{th} / R_{th} * \exp(-t / (R_{th} * C1))$

Power Across the Capacitor C1: $P_{c1} = V_{c1} * I_{c1}$

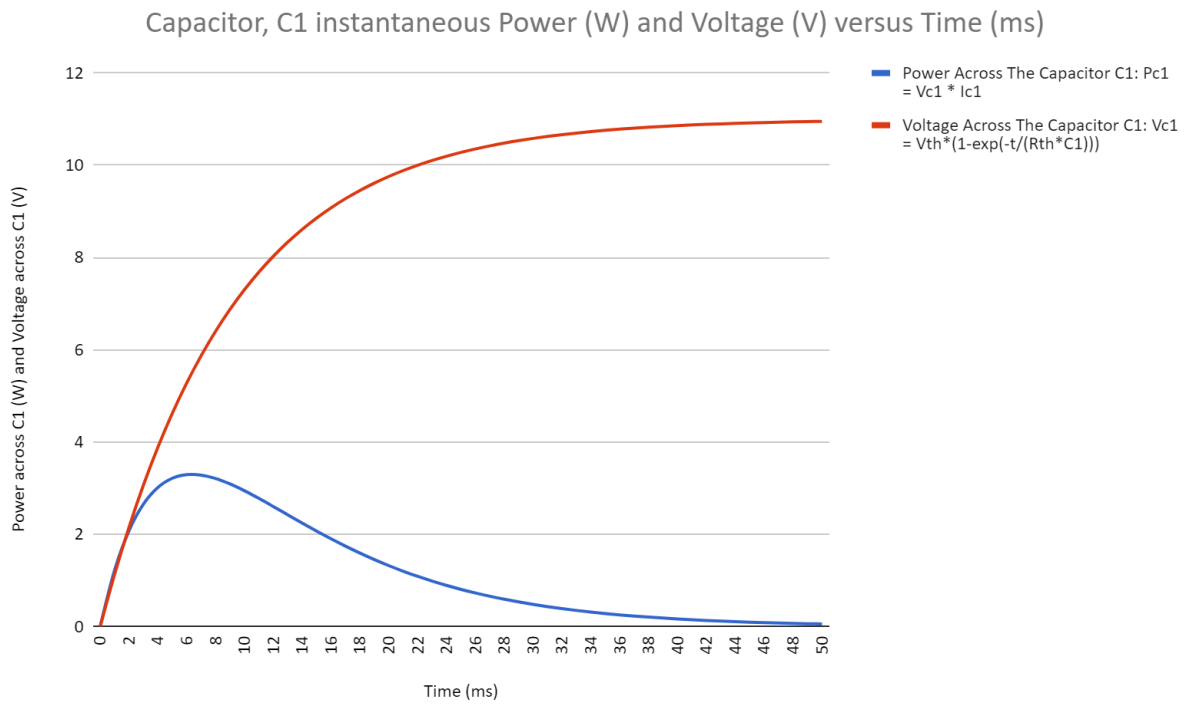

Figure 2: Capacitor Rating Calculations

4. Step 2: Simulations

Transient simulations show how well my circuit is working:

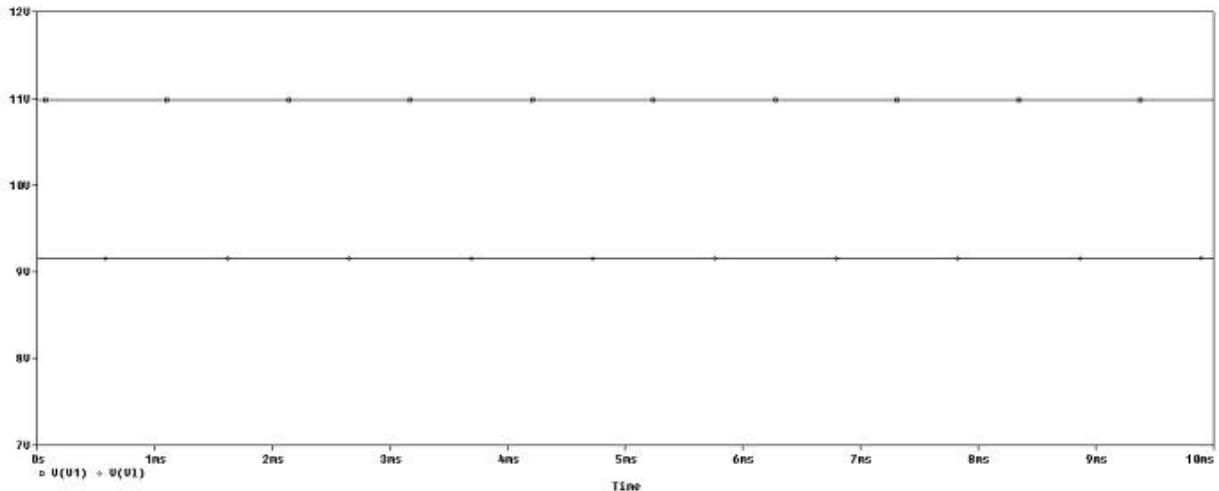

Figure 3: Transient Simulations

5. Conclusion

Designing this power supply was an easy task because inputs are DC (direct current) and not AC (alternative current). An alternative is the use of a power mixer. However, such a circuit might waste energy.

This circuit cannot be used as a power mixer. This is because the channel with the highest voltage could be the only channel driving the load with the other channels not being able to supply current due to diodes not allowing current to flow in reverse direction.